



TECHNICAL REGULATIONS FOR FORMULA JUNIOR CARS

These Technical Regulations have been prepared by way of assistance towards Formula Junior competitors. They are intended to be read in conjunction with FIA Appendix K. They should not be considered to be exhaustive.

NO OTHER MODIFICATIONS ARE PERMITTED

In general, except for what is otherwise explicitly authorised, any part damaged through wear or accident may only be replaced by a part which is identical in specification to (exactly the same as) the one for which it is substituted.

It should be clearly understood that if the following texts do not clearly specify that you can do it, then you should work on the principle that you cannot.

1. Principal and abbreviations

ASN	A national automobile club or other national body recognised by the FIA as sole holder of sporting power in a country.
EU	European Union
FIA	Fédération Internationale de l'Automobile
FJHRA	Formula Junior Historic Racing Association
HTP	Historic Technical Passport
Homologation	Homologation Forms and Recognition Forms endorsed by the FIA
HVIF	Historic Vehicle Identity Form
NEAFP	National Event with Authorised Foreign Participation

Historic Formula Junior races are for original Formula Junior cars, run with the original specifications. Cars are single-seater racing cars, whereof the fundamental elements are derived from a touring car recognised as such by the FIA. (Minimum production 1,000 units in twelve consecutive months).

The intention of Historic Formula Junior races is to re-create the 1958 - 1963 period of Formula Junior with cars prepared with due consideration to period detail and historical accuracy. General preparation should be to the highest possible standard to match those expected by the FJHRA.

The FIA has created the regulations in Appendix K so that Historic Cars may be used for competitions under a set of rules that preserve the specifications of their period and prevent the modifications of performance and behaviour which could arise through the application of modern technology.

2. General

2.1. All historic Formula Junior racing is governed by:

- 2.1.1. The original Rules of International Formula Junior 1959 - 1963 copies of which are available from FJHRA and are published on the FJHRA website www.formulajunior.com
- 2.1.2. FIA Appendix K - published annually in the FIA Yearbook and on the FIA website (<http://www.fia.com/sport/Regulations>) with amendments published in the FIA monthly bulletin. This document should be read in conjunction with Appendix K.
Appendix K generally requires that all Historic Competition cars will be preserved in the form in which they raced to these rules, except where safety considerations may enforce changes.
- 2.1.3. FIA Appendix J - published annually in the FIA Yearbook and on the FIA website (<http://www.fia.com/sport/Regulations>) Articles 251, 252, 253.
- 2.1.4. The Rules of the FIA Lurani Trophy (where generally applicable) - also published annually in the FIA Yearbook and the FIA website (<http://www.fia.com/sport/Regulations>).
- 2.1.5. These technical regulations which are published by the FJHRA to clarify the FIA Appendix K and Appendix J.
- 2.1.6. Any local variations imposed by local governing bodies.

2.2. Competitor eligibility

- 2.2.1. Entrants where applicable must be in possession of a valid Entrants Licence.
- 2.2.2. Drivers must be fully paid up valid racing members of the FJHRA, [and where applicable, have in addition paid any championship registration fees e.g. for the FIA Lurani Trophy Championship].

2.3. Competitor registration

- 2.3.1. FIA Lurani Trophy Championship
 - 2.3.1.1. All drivers must register as competitors for the FIA Lurani Trophy Championship by returning the completed Registration Form to the Co-ordinator prior to the Final Closing date of the first round being entered.
- 2.3.2. UK FJHRA/HSCC Millers Oils Formula Junior Championship
 - 2.3.2.1. All drivers must be full racing members of the HSCC and register as Competitors for the Championship by returning the Registration Form with the Registration Fee to the Formula Junior Historic Racing Association (FJHRA) prior to the Final Closing date for the first round being entered.

2.4. Class structure

- 2.4.1. Class A FIA Category FJ/1A
Front-engined Formula Junior cars fitted with Fiat or Lancia engines and built and raced before 31.12.1960.
- 2.4.2. Class B1 FIA Category FJ/1B
Front-engined Formula Junior cars built to race before 31.12.1960 (except cars falling within Class A), and) fitted with engines of 1000cc or less.
- 2.4.3. Class B2 FIA Category FJ/1B
Front-engined Formula Junior cars built to race before 31.12.1960 (except cars falling within Class A), and) fitted with engines of 1100cc but in excess of 1000cc.
- 2.4.4. Class C1 FIA Category FJ/1C
Rear-engined Formula Junior cars built and raced (or officially entered to race) before 31.12.1960, and, fitted with engines of 1000cc or less. For a list of eligible cars for this class, refer to Annex A.
- 2.4.5. Class C2 FIA Category FJ/1C
Rear-engined Formula Junior cars built and raced (or officially entered to race) before 31.12.1960, and, fitted with engines of 1100cc or less but in excess of 1000cc. For a list of eligible cars for this class, refer to Annex A.
- 2.4.6. Class D1 FIA Category FJ/2D
Rear-engined and front-engined Formula Junior cars built and raced between 01.01.1961 and 31.12.1963, and fitted with drum brakes on all four wheels, as original specification and fitted with engines of 1000cc or less. For a list of eligible cars for this class, refer to Annex A.
- 2.4.7. Class D2 FIA Category FJ/2D
Rear-engined and front-engined Formula Junior cars built and raced between 01.01.1961 and 31.12.1963, and fitted with drum brakes on all four wheels, as original specification and fitted with engines of 1100cc or less but in excess of 1000cc. For a list of eligible cars for this class, refer to Annex A.
- 2.4.8. Class E1 FIA Category FJ/2E
Rear-engined and front-engined Formula Junior cars built and raced between 01.01.1961 and 31.12.1963, and fitted with a disc brake or brakes.
- 2.4.9. Class E2 FIA Category FJ/2E
Rear-engined and front-engined Formula Junior cars fitted with engines other than Ford built and raced between 01.01.1961 and 31.12.1963, and fitted with a single pair of disc brakes or all disc brakes.

2.5. Eligibility

- 2.5.1. Historic Formula Junior is for original Formula Junior racing cars running to the original configuration of that car.
- 2.5.2. It is not necessary for a Formula Junior car to prove International competition history in period.
- 2.5.3. Only genuine and original cars from the correct period will be accepted. To be eligible to participate as a Formula Junior car, the car must have been constructed in period to the specification of FIA Formula Junior. Continuation cars or modern replicas are not permitted.
- 2.5.4. To be eligible to race that car must have a proven continuous history since period and either:
 - 2.5.4.1. is in a specification that represents the standard specification for that model; or
 - 2.5.4.2. is in an alternative specification which can be proved by contemporary evidence [documents and/or photographs] as being the period specification for that particular chassis.

“Continuous history since period” may be satisfied if that car formerly held an FIA HVIF; or a National passport issued prior to 1st January 2000.
- 2.5.5. “CAR” means each and every one of the six principal components.
 - 2.5.5.1. Chassis.
 - 2.5.5.2. Engine – make and model [subject to paragraph 6.4.12. hereof].
 - 2.5.5.3. Gearbox – {subject to paragraph 6.10. hereof}
 - 2.5.5.4. Brakes.
 - 2.5.5.5. Rear axle.
 - 2.5.5.6. Wheel [diameter] – [subject to paragraph 6.13. hereof].
- 2.5.6. Alternative components other than to the manufacturers original specification can only be used if it is proved that these components were used in that particular car in an FIA International event in the Formula Junior period.
- 2.5.7. Cars may be permitted to compete at the sole discretion of FJHRA on a PROVISIONAL basis where the Car appears likely to satisfy the criteria of 2.5.5. pending complete evidence and documentation.
- 2.5.8. The following are specific examples (which are NOT exhaustive) of changes that are not permitted.
 - 2.5.8.1. Gemini MkII, BMC engine changed to Ford engine.
 - 2.5.8.2. Elva 100, DKW to BMC engine, (except if such change was effected on proven evidence prior to 1995).
 - 2.5.8.3. Cooper T59, BMC engine to Ford engine.
 - 2.5.8.4. Lotus 18, Renault Dauphine 4 speed gearbox (Type 318) to any other make or type.
 - 2.5.8.5. A Ford engine will not be allowed to be fitted to an Elva 100, except to the one chassis that was so fitted in period.
 - 2.5.8.6. A Stanguellini will only be permitted to use a gearbox with 5 forward ratio's if it can be proven that the actual chassis was fitted with such a gearbox before the end of Period E.
- 2.5.9. Class B. FIA Category Period E (FJ1)
All front engined cars are Period E (FJ1) except the Mallock U2 Mk 2B and Mk3 which are Period F (FJ2).
- 2.5.10. Appendix K provides that alternative components other than to the manufacturers original specification can only be used if it is proved that these components were used in that particular car in an FIA International event in the Formula Junior period.
- 2.5.11. Subject to para 6.4.12. no car may take part in a Formula Junior race with a specification of a period (class) which is different from the period in which it is classified.

3. Date Classification and Definition

3.1. Date classification

- 3.1.1. Historic Formula Junior is open to original single seat Formula Junior cars which were manufactured and raced before 31/12/1963.

3.2. Period specification

- 3.2.1. There are several "period specifications" that are relevant to Formula Junior cars. A definition of each period is listed below:
- 3.2.1.1. FIA Period E: (Single-seater cars). 1 January 1947 – 31 December 1960
 - 3.2.1.2. FIA Period F: 1 January 1961 – 31 December 1965
 - 3.2.1.3. FIA FJ1 Period (Classes A,B,C) 1 January 1958 – 31 December 1960
 - 3.2.1.4. FIA FJ2 Period (Classes D,E) 1 January 1961 – 31 December 1963
 - 3.2.1.5. Formula Junior Period 1 January 1958 – 31 December 1963
- 3.2.2. Although FJ2 Formula Junior cars fall within the FIA Period F (1 January 1961 – 31 December 1965), it does not follow that all of the regulations published in Appendix K relating to Period F cars apply retrospectively to FIA Period FJ2 – Formula Junior cars. The Period relating to FJ2 cars ended on 31/12/1963.

4. Vehicle Identity Documents

4.1. Historic Technical Passport (HTP)

- 4.1.1. To compete in the FIA Lurani Trophy for Formula Junior cars, every car shall have an FIA HTP. When the car is presented for scrutineering, the certificate (HTP) as issued by the national sports authority (ASN) concerned must be available and state the origin of its fundamental elements.
During the year, it is possible that spot-checks will be conducted by the Championships' Eligibility Scrutineer to ensure continuing compliance with the declared specification on the HTP.
- 4.1.2. To be eligible to obtain an HTP as a Formula Junior car, the car must have been constructed in period to the specification of FIA Formula Junior. It is not necessary for a Formula Junior car to prove International competition history in period.
- 4.1.3. An HTP is strongly recommended but is not obligatory for all cars.
- 4.1.4. An HTP is obligatory for all races in Europe, inserted on the International calendar or the FIA calendar as NEAFP.

5. Safety Prescriptions

5.1. General

- 5.1.1. All of the regulations in this safety section are compulsory.
- 5.1.2. In all respects cars will be required to comply with any general regulations relating to safety as defined within the various sections of these regulations and they will have to comply with any regulations pertaining to the country that the cars would normally compete in.
- 5.1.3. Providing all safety regulations are complied with, if it complies with the original specification the petrol tank, oil tank, battery and fire extinguisher may be located in the driver cockpit space.
- 5.1.4. For FIA races, drivers must comply with the requirements of Appendix L to the International Sporting Code concerning crash helmets, fire resistant clothing and licences.
- 5.1.5. Drivers must wear overalls as well as gloves, long underwear, a balaclava, socks and shoes homologated to the FIA 8856–2000 standard.
- 5.1.6. Drivers must wear gloves in a high-visibility colour which contrasts with the predominant colour of the car, so that the driver can clearly draw the attention of the race starter in case of difficulties.

5.2. Condition to take part.

- 5.2.1. Cars must be presented clean and in a safe condition to take part.

5.3. Battery, circuit breaker

- 5.3.1. Cars must be equipped with a circuit breaker. The circuit breaker, when operated, must stop the engine and isolate all electrical circuits with the exception of those that operate fire extinguishers. The location of the circuit breaker must be identified by a red spark on a white-edged blue triangle (12cm base) and the 'On' and 'Off' positions clearly marked.
- 5.3.2. The battery earth lead should be identified by a yellow marking.
- 5.3.3. Batteries must be protected to exclude leakage of acid and to protect terminals from short circuiting and producing sparks.
- 5.3.4. Any wet batteries in the driver compartment must be enclosed in a securely located, leak-proof container.

5.4. Pipelines, cables and electrical equipment

- 5.4.1. All pipes carrying liquid coolant must be clearly marked with red paint, red tape or red heat shrink tubing to give a warning that the pipeline is carrying potentially scalding fluid. Joints should be avoided in the driver cockpit; screwed hose clips may only be used in conjunction with a suitably swaged pipe.
- 5.4.2. It is strongly advised that no fluids shall pass through the chassis tubes in a space frame vehicle.
- 5.4.3. All wiring should be secured and well protected to reduce the risk of fire from electrical shorts.
- 5.4.4. Cars must be equipped with an internal switch that is capable of isolating all electrical circuits (excluding any controlling the fire extinguishers) and completely stopping the engine. The operating switch must be positioned so that it can be operated by the driver when normally seated with seat belts fastened.
- 5.4.5. If a camera/video recorder is carried, the fitting of such equipment must be in position at the time of scrutineering and specifically approved by a scrutineer and the race organisers.

5.5. Fuel system

- 5.5.1. All safety (bag) tanks must comply with Article 253.14 of current Appendix J (FIA Approved Safety Fuel Tanks).
- 5.5.2. No safety (bag) tank may last over 5 years, unless it has been re-inspected and validated for 2 more years. Manufacturers of such items will issue a certificate and this must be available at scrutineering and upon demand from the FIA steward.
- 5.5.3. All fuel cells have to be date "stamped". The onus is upon the driver to prove that the cell is "in date". If the certificate or the manufacturers plate is not available, then the competitor must be prepared to remove the cell in order for the date printed on the walls of the cell to be checked. It is recommended that any safety cell is periodically inspected on a regular basis.
- 5.5.4. For FJ1 cars not fitted with a fuel cell or 'bag tank' it is strongly recommended that fuel tanks should be filled with fuel tank safety foam which reduces surge and the risk of explosion. This is mandatory for all FJ2 (Period F) cars.

5.6. Bulkheads

- 5.6.1. Period E cars – Bulkheads are not mandatory but are strongly recommended.
- 5.6.2. Period F cars – All cars must have a protective bulkhead of non-flammable material between the engine and the driver/passenger compartment. It is recommended that gaps are sealed with GRP or intumescent putty.
- 5.6.3. It is recommended that cars have a bulkhead between any fuel tank and filler and the driver/passenger compartment.
- 5.6.4. It is recommended that cars have the radiator carrying engine coolant isolated from the cockpit or a suitable deflector fitted to prevent fluid directly coming into contact with the driver.
- 5.6.5. It is recommended that cars have the master cylinders and/or remote reservoirs carrying brake/clutch fluid isolated from the cockpit or a suitable deflector fitted to prevent the fluid directly coming into contact with the driver. Most types of hydraulic fluids are flammable.

Prohibitions:

- 5.6.6. The use of magnesium is prohibited for bulkheads.

5.7. Fire extinguisher

- 5.7.1. All cars must be equipped with at least a hand operated fire extinguisher complying with current Appendix J, Article 253.7.3. [NB: until 31 December 2003 all cars in period F had to have a semi-automatic (driver operated) system, discharging into the engine compartment, conforming to the requirement for open cars in Article 259.14.1 of Appendix J. This is now only optional in the new Appendix K].
- 5.7.2. An extinguishing system homologated by the FIA in accordance with current Appendix J, Article 253.7.2 (Technical List 16) is recommended, with the exception that the external means of triggering required by Article 253.7.2.3 is not mandatory.
- 5.7.3. All plumbed-in extinguisher systems must in be an 'ARMED' condition at all times whilst competing or practising and must be FIA homologated for use in FIA events e.g. Lurani Trophy.
- 5.7.4. Extinguishers systems should have the weight of the extinguishant, the operating mechanism and the integrity of the cylinder checked and serviced in accordance with the manufacturers instructions. The tare weight of the unit must be marked on the cylinder.
- 5.7.5. The following information must be visible on each extinguisher:
 - 5.7.5.1. The capacity.
 - 5.7.5.2. The type of extinguisher.
 - 5.7.5.3. The tare weight or volume of the extinguisher.
 - 5.7.5.4. The date the extinguisher was last checked, which must be no more than two years after either the date of filling or the date of the last check.
- 5.7.6. All extinguishers must be adequately protected. Their mountings must be able to withstand a deceleration of 25g. Furthermore, in the case of hand held manual extinguishers only quick-release metal fastenings, with metal straps, will be accepted.
It is mandatory to have two straps which either bolt or screw to hold the fire extinguisher to the bracket, i.e. large jubilee (worm drive) clips.
- 5.7.7. In the case of manual extinguisher/s they must be easily accessible for the driver.
- Prohibitions:**
- 5.7.8. BCF and Dry powder extinguishant is prohibited.

5.8. Oil catch tanks

- 5.8.1. Cars must have any engine oil tank breather or overflow tube venting to atmosphere, led into catch tanks which have a minimum capacity of 2 litres to prevent oil spilling onto the track.

5.9. Throttles

- 5.9.1. Additional external throttle return springs must be fitted, one per bank of throttles. The engine must be equipped with a positive method of throttle closing by means of external spring/s so that in the event of failure of any part of the throttle linkage the throttle(s) are sprung closed.

5.10. Rear-view mirrors

- 5.10.1. All cars must have at least two mirrors mounted so that the driver has visibility to the rear and both sides of the car. The mirrors shall have a minimum total glass area of 90 cm².

5.11. Lamps

- 5.11.1. Not applicable.

5.12. Windscreens

- 5.12.1. The screen must be to the original size and it may be made of rigid transparent plastic.

5.13. Roll over protection structure (ROPS)

- 5.13.1. All cars (Period E (FJ1) and Period F (FJ2) must be fitted with a roll over protection structure meeting or exceeding the specification used on the car when it was used in competition in period as the minimum standard. A period specification ROPS is defined as one that was used in competition in period on the actual make and model of car. The competitor must provide evidence of the period specification when requested.

Period E - (FJ1) Classes A, B, and C

- 5.13.2. It is strongly recommended that FJ1 cars respect the 5 cm clearance over the driver's helmet shown in Fig. 1.

- 5.13.3. Cars in Period E (Category FJ1) roll over protection may be updated to the roll over hoop specified for Period F cars.
- 5.13.4. Any Period E car fitted with a roll over protection structure **must** be equipped with an in date FIA homologated safety harness.

Period F - (FJ2) Classes D, and E

- 5.13.5. An appropriate roll over protection structure providing adequate protection is obligatory.
- 5.13.6. Period F cars (Category FJ2) must be fitted with a roll over protection conforming to period specification **or** to Art.277 of 1993 Appendix J - Appendix VI A in the current version of FIA Appendix K to the Sporting Regulations.
Except for ROPS of free structural conception and certified to withstand the stress minima as per 5.13.13., the tubes of the main rollbar and braces must have dimensions not less than those mentioned below.
- 5.13.7. For Period F, roll over protection must be a minimum of 5 cm above the top of the driver's helmet when the driver is sitting in the normal driving position, with seat belts fastened and well tightened.

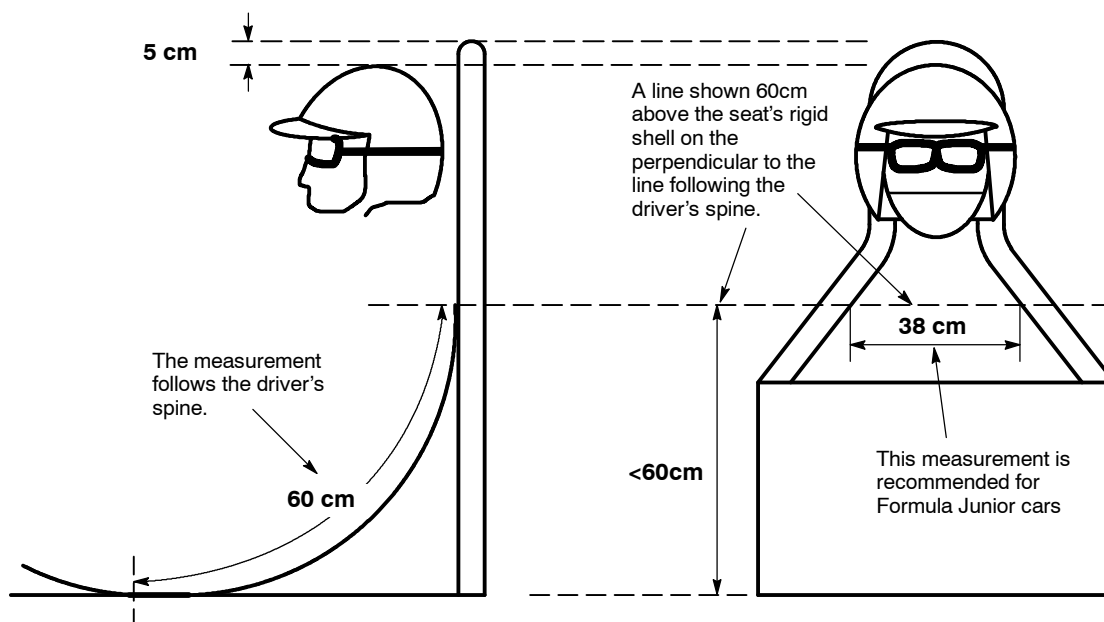

Fig 1. Roll over hoop dimensions [Drawing K62 from Appendix K]

Roll over hoop

- 5.13.8. The roll over hoop is a single piece tubular hoop that is located transversally across the vehicle, near-vertical (recommended maximum angle $\pm 10^\circ$ to the vertical) and located just behind the driver's seat. The surface of the bends must be smooth and even without unevenness, ripples or cracks.

Dimensions

The dimensions of the roll over hoop must be as follows:-

- 5.13.9. If a non-original ROPS is fitted to the car, the tubes of the main rollbar and braces must have dimensions not less than those listed in Article 277 of Appendix J 1993 (Appendix VI A in FIA Appendix K to the Sporting Regulations).
- 5.13.10. The top of the roll over hoop must be at least 5cm above the driver's helmet when the driver is sitting in normal driving position.
- 5.13.11. It is recommended that the width of the rollbar is at least 38 cm, measured inside the rollbar between the two pillars forming the sides of the hoop. It must be measured, horizontally and parallel to the driver's shoulders, at a distance of 60 cm (following the driver's spine) above the base of the seat's rigid shell.
This dimension is not mandatory for Formula Junior cars as all Formula Junior cars conform entirely to a pre 1969 specification. The "Year Asserted" on the car's HTP will be used to establish the ROPS specification required.

- 5.13.12. The tubing must be bent by a cold working process and the centreline bend radius must be at least 3 times the tube diameter. If the tubing is ovalised during bending, the ratio of minor to major diameter must be 0.9 or greater.

Strength

- 5.13.13. In order to obtain a sufficient strength for the rollbar, two possibilities are left to the constructor.
- a.) The ROPS, of entirely free structural conception, must be capable to withstand the stress minima indicated in article 275.15.3.3, i.e.:
- 1.5 w lateral
 - 5.5 w fore and aft
 - 7.5 w vertical
- with w being 740 kg.
- b.) The tubes and brace(s) must have a diameter of at least 1 3/8 inch (3.5 cm) and at least 0.090 inch (2 mm) wall thickness.
- Where option a) is used, a certificate to substantiate the strength of the ROPS must be presented.

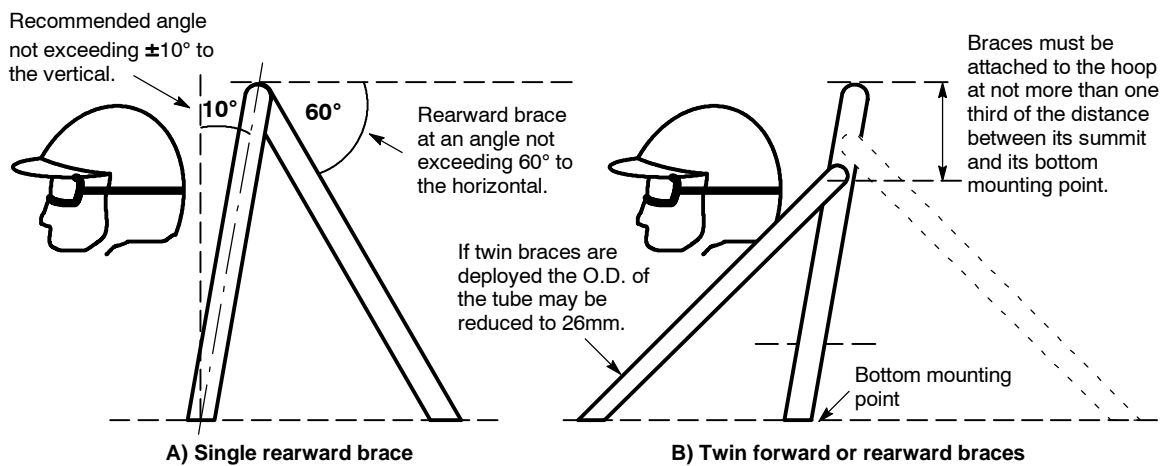

Fig 2. Roll over protection structure bracing guidelines

Materials

- 5.13.14. Only tubes with a circular section are authorised.
- 5.13.15. The tubes and brace(s) must have a diameter of at least 1 3/8 inch (3.5 cm) and at least 0.090 inch, (2 mm), or 14 SWG wall thickness.
- 5.13.16. The material should be molybdenum chromium SAE 4130 or SAE 4125 (or equivalent in DIN, NF, etc.) or cold drawn low carbon seamless steel tube.
- 5.13.17. There must be at least one brace from the top of the bar rearwards at an angle not exceeding 60° to the horizontal.
- 5.13.18. Braces must be attached to the main hoop at a distance from its summit of not more than one third of the distance between its summit and its bottom mounting point; such braces must not impede the exit of the driver from the car.
- 5.13.19. The diameter and material of the brace must be the same as those of the rollbar itself. In the case of the use of two braces, the diameter of each of them may be reduced to 26mm external O.D. and 20 mm I.D. - [3mm wall thickness (10 SWG)].
- 5.13.20. Removable connections between the main hoop and the brace must comply with Appendix K drawings K-39 to K-49.
- 5.13.21. Forward fitted braces are allowed, but they must not must not unduly impede the entry or exit of the driver.
- 5.13.22. Welding must be carried out along the whole perimeter of the tube. All welding must be of the highest quality possible with full penetration. Although good outside appearance of a weld does not necessarily guarantee its quality, poor looking welds are never a sign of good workmanship.
- 5.13.23. Any bolts used should be of a sufficient minimum diameter, according to the number used. They must be of the highest possible quality (minimum Grade 8.8).

-
- 5.13.24. Any spherical joints used should be of a sufficient minimum thread diameter and they must be of the highest possible quality.
 - 5.13.25. Cars not able to fully comply with the above requirements may be granted a special dispensation subject to approval by HMSC. Confirmation of the dispensation must be appended to the car's HTP.
 - 5.13.26. Consideration should be given to the design of the roll over hoop in order to provide sufficient strength for towing and lifting the car during recovery from the circuit by the marshals.

Prohibitions:

- 5.13.27. Aluminium alloy roll over hoops are prohibited.
- 5.13.28. Extensions added above the main structure to increase the height are forbidden unless covered by an FIA Roll Cage Certificate.
- 5.13.29. Tubes must not carry fluid or any other item.

5.14. Headrests

- 5.14.1. A headrest/head restraint must be fitted and located such that the drivers head/helmet is restrained and cannot move past it under rearward forces, or be trapped between the roll over bar and the head restraint. It is recommended that it be within 5cm of the driver's helmet when they are normally seated.

5.15. Red rear lights

- 5.15.1. All cars must be equipped with a working red warning "rain light" facing rearwards. This warning light must be fitted with a bulb of a minimum of 21 watts, with a surface area minimum 20cm² with the lens and reflector to EU Standards and must be located within 10cm of the centre line of the car. an alternative light unit of equal or enhance constant luminosity or LED lights that are either homologated by the FIA or comply with relevant EU Regulations may be used. Where LED lights are used, at least 90% of the elements must be operational.

5.16. Safety belts

- 5.16.1. All seat belts used must be in date and currently homologated by the FIA.
- 5.16.2. FJ1 [Period E] – Seat belts are compulsory if the car has a roll over bar fitted. If no roll over bar is present, then seat belts are recommended but not compulsory, but if they are fitted, then they must be to the same specification as for FJ2.
- 5.16.3. FJ2 [Period F] – FIA homologated seat belts are mandatory.

5.17. Engine cover

- 5.17.1. An engine cover must be fitted and must be adequately fastened.

5.18. Towing-eyes

- 5.18.1. Cars must have clearly visible towing points clearly marked and identified in yellow. This towing point can be the top of the roll over hoop. Refer to 5.13.26.

5.19. Steering, removable wheel

- 5.19.1. Whilst it is preferable to retain the original period steering wheel, an alternative steering wheel of different diameter and/or style may be fitted.
- 5.19.2. Although not a period item, in the interests of safety "quick release" steering wheel hubs are permitted.
- 5.19.3. One piece steering columns may be replaced by columns having universal joints or telescopic devices for safety reasons providing that all original functions remain.

5.20. Condition testing

- 5.20.1. Not required for Formula Junior categories at the present time.

5.21. Repairs

- 5.21.1. Must be carried out to the original manufacturers standard. Replacement chassis tubes must be the same as the original outside dimension and with the same wall thickness as the original gauge.

5.22. Seats

- 5.22.1. Original seats are often found to be of inadequate construction. You are recommended to regularly check, strengthen or replace this component with one with a better specification.

6. Technical Regulations and Exceptions

6.1. Introduction

- 6.1.1. The position of FJHRA is simple. Historic Formula Junior races are for original cars, in original specification.
- 6.1.2. All modifications are forbidden unless expressly authorised by these regulations or by the general prescriptions imposed under the heading Article 5 "Safety Prescriptions".
- 6.1.3. Doubts as to the eligibility of any vehicle or individual component must be clarified in writing by the FJHRA via the Technical Officer.
- 6.1.4. It is the duty of each competitor to satisfy the Scrutineers and the Stewards of the meeting that his automobile complies with these regulations in their entirety at all times during the event.
- 6.1.5. Alternative components: Freedoms granted in period by Appendix J do not now confer complete freedom but rather authorise the use of modification and/or components actually used in period on the particular make and model as a result of those period freedoms.
- 6.1.6. It should be clearly understood that if the following texts do not clearly specify that you can do it, then you should work on the principle that you cannot.

6.2. Chassis/Monocoque

- 6.2.1. The chassis must conform to the original design, dimensions and construction.
- 6.2.2. It is only permitted to strengthen the chassis as required to support roll hoops, seat belt anchors, fire bottles, or any other equipment which increases the safety factor of the vehicle.
- 6.2.3. By way of clarification, the chassis used in all cars must have provenance in conformity with 3.1. It is **STRONGLY** recommended that **NO** new chassis are used. If it is necessary to replace or re-build any chassis, then as much material as possible must be retained from the original chassis and it must be grafted in to the 'new' chassis, which itself must be constructed as a direct copy of the original chassis including materials used and the construction methods.
Any manufacturers' original chassis plate must be transferred to the 'new' chassis and the old chassis/sections must be destroyed. It is at all times the responsibility of the competitor to prove provenance on demand of the Technical Officer and all such replacement chassis must be declared by the competitor to the Championship Technical Officer in writing.
- 6.2.4. Any ballast required to achieve the minimum weight must be attached to the chassis in a secure manner in such a way that tools are required for its removal. Provision must be made for the fixation of seals by scrutineers if deemed necessary.
- 6.2.5. The use of "powder-coating" as a protective finish to the chassis is permitted as an alternative to the traditional painted finish.

Prohibitions:

- 6.2.6. Additional strengthening of the chassis/monocoque is not permitted.
- 6.2.7. It is not permitted to change the size outside diameter (O.D.) or thickness (SWG) of the tubing or sheet in the repair of the chassis. The diameter and the gauge of any tubing or sheet used must be as per the original [e.g. if the chassis was originally constructed from Imperial tubing, then any replacement chassis tubes must be Imperial (not metric)].
- 6.2.8. It is not permitted to add any additional triangulation in the form of additional tubes or gussets to the chassis structure.

6.3. Front and rear suspension

- 6.3.1. Suspension e.g. radius arms, wishbones etc. shall not be adjustable unless originally manufactured in this form.
- 6.3.2. If the car is fitted with an "inboard" suspension, the original rocker and shock absorber axis on the chassis must be maintained.
- 6.3.3. The system of suspension (spring type and location of wheels or axles) must not be altered nor must any additional location or springing medium be added unless this was a period specification.
- 6.3.4. Anti-roll bars and telescopic shock absorbers are only permitted if included in the period specification. Anti-roll bars shall be made from a solid bar.

- 6.3.5. Adjustable spring platforms may be used on all cars of which the period specification included concentric coil spring/shock absorber units.
 - 6.3.6. Spherical (Rose) joints may only be used if a period specification. Rose joints may also be used on anti-roll bars on period F cars providing that the geometry of the suspension is not affected.
 - 6.3.7. Beam and live axles should be of original design must use the same location points and the same shock absorber mounting points.
 - 6.3.8. Shock absorbers must be in accordance with Appendix K, ie, to period specifications.
 - 6.3.9. Shock absorbers must be steel bodied period items.
 - 6.3.10. Shock absorbers must be mounted in the original location using the original mounting points.
 - 6.3.11. Suspension bushes may be changed from bonded rubber bushes to 'poly' bushes provided that this does not result in a change in the dimensions.
 - 6.3.12. Spherical bearings on shock absorbers are not permitted on Period E cars unless they were a period specification for that car.
- Prohibitions:**
- 6.3.13. It is not permitted to alter the suspension geometry from the original design.
 - 6.3.14. It is not permitted to utilise a shock absorber with independent adjustment for bump and rebound (double adjustable).
 - 6.3.15. It is not permitted to utilise any single adjustable shock absorber which is gas filled/gas pressurised.
 - 6.3.16. It is not permitted to utilise any alloy bodied shock absorber.
 - 6.3.17. It is not permitted to utilise any shock absorber with remote reservoirs.

6.4. Engine

General

- 6.4.1. The engine components and ancillaries must be of period specification, must be of the same make, model and type fitted and conform to a manufacturer's specification for which period evidence exists.
- 6.4.2. The car must be in the configuration as designed by the manufacturer, with the engine in the original location.
- 6.4.3. Engine tuning is permitted within the following limitations.
- 6.4.4. All of the regulations in this general section apply to all eligible engines.
- 6.4.5. The engine must come from a FIA homologated touring car from FIA Period E or Period F, (up to the end of 1963), the end of the Formula Junior period.
- 6.4.6. The cylinder block, including the cylinder-head and the cylinders (if the latter are removable) must be those of the engine belonging to the car classified by the FIA in the Touring category.
- 6.4.7. The cylinder capacities, specified in the present regulations, may be achieved by modifying the original bore (increase or reduction). No modifications of the stroke are permitted.
- 6.4.8. Swept volume must not exceed 1100cc measured at the point of maximum ring travel.
- 6.4.9. The crankshaft is free, but it must retain the original stroke, refer to 6.4.5.
- 6.4.10. The number of valve ports must conform to a period specification.
- 6.4.11. Although not yet mandatory, it is recommended that all engines should have cross-drilled bolts/nuts/studs sufficient to enable the rocker cover and/or cylinder head and sump pan to be wire sealed to the engine block at any time.
- 6.4.12. The engine specification shall be for the whole period of Formula Junior and shall not be restricted to the period of the two individual categories. For example :-
 - 6.4.12.1. The Ford 109E and 105E engine blocks are both permitted for the FJ/1 categories.
 - 6.4.12.2. 1100cc Ford, B.M.C. and D.K.W. engines are all permitted in the FJ/1 categories in place of similar 1000cc engines, although entrants are encouraged to retain the 1000cc engine where originally fitted to that chassis.
- 6.4.13. Machining, polishing and balancing of the engine parts is authorised.
- 6.4.14. Pistons design is free. Pistons may be altered, or alternative pistons may be used as long as they do not use any modern anti-friction or thermal barrier coatings, see 6.4.26.

- 6.4.15. Valve train, camshafts, valves and valve springs of different specification or manufacture may be used, provided that the number employed does not exceed that of the homologated engine.
- 6.4.16. Connecting rods are free provided they are made of ferrous metal.
- 6.4.17. The use of steel main bearing caps is permitted but the centres of the mounting holes must remain in the original location.
- 6.4.18. The use of higher grade fasteners is permitted. This must be read in conjunction with specific prohibitions listed below.
- 6.4.19. The camshaft is free, but must remain in the manufacturers original position and be the sole means of operating the push rods and valves.
- 6.4.20. Rocker ratio is free.
- 6.4.21. Compression ratio is free, but due consideration should be made to the grade of fuel required by the regulations.
- 6.4.22. The increase of the compression ratio through machining the cylinder head or block, or using a thinner gasket or doing without one, is authorised.
- 6.4.23. Gasket material is free. Modern multi layer steel (MLS) head gaskets are acceptable.

Prohibitions:

- 6.4.24. It is not permitted to alter the stroke of the crankshaft.
- 6.4.25. It is not permitted to use non iron cylinder heads and/or engine blocks unless they were homologated in period.
- 6.4.26. It is not permitted to use pistons that utilise any form of modern coating, e.g. ceramic, Xylan/DLC, PTFE (Teflon) or any thermal barrier, low friction, anti-scuffing or similar coating.
- 6.4.27. It is not permitted to use an engine with one or more overhead camshafts.
- 6.4.28. It is not permitted to change the location of the camshaft.
- 6.4.29. In Period E (FJ1), it is not permitted to use a gear driven camshaft, the camshaft must be chain driven.
- 6.4.30. It is not permitted to change the number of crankshaft bearings.
- 6.4.31. It is not permitted to use roller rockers.
- 6.4.32. It is not permitted to use light alloy (aluminium, titanium) valve spring caps/retainers. The material must be magnetic.
- 6.4.33. It is not permitted to use any titanium parts.
- 6.4.34. It is not permitted to use water pump tooth drive belts on FJ1 (Period E) cars. The only acceptable water pump drive belt is the "V" type belt.
- 6.4.35. It is not permitted to use the ribbed (multiple V-belt) drives for the water pump.
- 6.4.36. It is not permitted to use an engine management system.

Specific regulations

The following regulations apply to the preparation of engines from the following manufacturers.

BMC engines

- 6.4.37. Cars powered by BMC engines may use the cylinder head bearing the casting number 12G940 as a replacement for the original head.
- 6.4.38. The engines allowable are as follows:-

	cc	Stroke	Original Bore
Morris Minor/A35/Sprite	948	76.2mm	62.92mm
Mini Cooper 61-63	997	81.5mm	62.42mm
Morris Minor Sprite/Midget	1098	83.72mm	64.58mm
Mini Cooper XSP FJ	1071	68.26mm	70.61mm

Prohibitions:

- 6.4.39. It is not permitted to use a crankshaft with a stroke of 62mm, as used in the Cooper 970 'S' engine from 1964 (F3).

Fiat engines

- 6.4.40. Cars powered by Fiat engines may use blocks of the 103 types 'D' and 'H' engines which have a standard 68mm bore (equating to 1098cc) to replace the original 1100/103 block. The use of the later 103P and 103R blocks is prohibited.

- 6.4.41. The FIAT 1100 engine block 103 Type G (which has a standard 72mm cylinder bore, provided this is reduced to 68mm) may also be used to replace the 1100/103 block having the serial number 103H.

Ford engines

- 6.4.42. Cars powered by Ford engines must use blocks bearing the casting code 105E or 109E. The use of these blocks is for the whole period of Formula Junior (for example, the Ford 109E and 105E engine blocks are both permitted for FJ/1 category). The use of later, five bearing blocks is prohibited.
- 6.4.43. It is permitted to utilise any of the original equipment Ford pre-crossflow cylinder head castings.
- 6.4.44. The use of the Formula Junior cylinder head manufactured by Geoff Richardson Engineering to the original specification of the Cosworth side draught head is permissible in FJ2 only.
- 6.4.45. Any car in Class B or C fitted with the Richardson head which would otherwise be eligible for these classes but for the Richardson head, shall be admitted to Class D.

6.5. Ignition

- 6.5.1. Electronic ignition is permissible on cars built after 31/12/1960 (i.e. FJ2 only) provided that the system utilises contact breaker points or is magnetically coupled (Hall effect switch) and uses a distributor and rotor arm to switch the high tension current and utilises an ignition coil with a minimum resistance of 3 ohms. The Lucas system is the preferred electronic ignition system.
- 6.5.2. A single coil and distributor must be used.
- 6.5.3. An electronic rev limiter may be used for all Historic Formula Junior cars.
- Prohibitions:**
- 6.5.4. It is not permitted to use electronic ignition on cars in the FJ1 category.
- 6.5.5. It is not permitted to use a system that uses infra-red optically controlled “breaker” system, in place of the points.

6.6. Lubrication

- 6.6.1. The number and type of oil pumps and the length of external oil piping used must conform to period specifications.
- 6.6.2. Fixed or mobile sump baffles and gates are permissible.
- 6.6.3. The oil pump must fitted in its original location. Oil pump drive should be as original.
- 6.6.4. Oil coolers may be fitted if not a period specification, but must be positioned so as not to change the silhouette.
- 6.6.5. Oil lines must be protected externally against any risk of deterioration (stones, corrosion, mechanical breakage, etc.) and internally against all risks of fire.
- 6.6.6. The specification of the lubricant utilised is free.
- Prohibitions:**
- 6.6.7. It is not permitted to change the system of engine lubrication from wet sump to dry sump for FJ1 category.
- 6.6.8. On wet sump engines (Period FJ1) it is not permitted to use a front mounted oil pump.
- 6.6.9. The use of oil accumulators are not permitted.
- 6.6.10. It is not permitted to fit an electrically driven oil pump.

6.7. Fuel system

- 6.7.1. Carburettors from the same or an earlier period may be used, but only if the components are of the same number and general type and principle of operation as those originally fitted.
- 6.7.2. The system and principle of feeding by carburettor or injection, must be the same as on the car from which the engine is taken.
- 6.7.3. It is strongly recommended, that cars of both FJ/1 and FJ2 retain the original make, model and type of carburettors as fitted in period, but subject to the further provisions of this paragraph 10 it is permitted to use a Weber carburettor of period specification to replace an SU or AMAL carburettor.
- 6.7.4. The maximum permissible size of carburettor when a pair of twin sidedraughts are used is 40 eg. 40DCOE.

- 6.7.5. The maximum permissible size of carburettor when a single twin choke sidedraught carburettor is used is a 45.
- 6.7.6. The maximum permissible size of carburettor when a pair of SU's are used is 1¹/₂ inch.
- 6.7.7. The maximum permissible size of carburettor when a single SU carburettor is used 1³/₄ inch.
- 6.7.8. It is permitted to use the modern reproduction Weber carburettor of Spanish manufacture but to original specification.
- 6.7.9. Air filters are optional.
- 6.7.10. Chokes (throat), inlet trumpets, needles and jets sizes are free.
- 6.7.11. The type and specification of the fuel pump/s utilised is free.
- 6.7.12. Fuel lines must be protected externally against any risk of deterioration (stones, corrosion, mechanical breakage, etc.) and internally against all risks of fire.
- 6.7.13. Any fuel lines or tubes that may carry fuel passing through the driver/passenger compartment must be protected and, if non-metallic, must be internally or externally metal braided hydraulic pressure hoses or fuel lines complying with FIA Appendix J Article 253 3.2. They may only be joined by screw sealing joints or vehicle manufacturer approved joints.
- 6.7.14. Only commercial fuel as laid down and defined by the FIA shall be used.
- 6.7.15. With the exception of 2-stroke engines, additional lubricating compounds, not exceeding 2% by volume, may be added to the fuel.
- 6.7.16. Compounds, which are added to fuel to replace lead, may be added if freely available from commercial retailers. The addition of these compounds must not raise the octane value of the unleaded fuel beyond the limit of 90 MON or 102 RON, or leaded fuel beyond 92 MON or 100 RON.
- 6.7.17. The fuel must be commercial petrol which comes from a service station pump, without any additive other than that of a lubricant on current sale. The fuel must comply with FIA specifications:
 - 6.7.17.1. Unleaded fuel 102.0 RON and 90.0 MON maximum
 - 6.7.17.2. Leaded fuel 100.0 RON and 92.0 MON maximum
- 6.7.18. Only air may be mixed with the fuel as an oxidant.
- 6.7.19. Inlet manifolds can be of alloy, steel or stainless steel and can be of cast or welded construction.
- 6.7.20. All quick release (Monza type) fuel caps protruding outside the silhouette of the bodywork must be fitted with a secondary device to prevent accidental opening.
- 6.7.21. It is recommended that all cars are fitted with a one way safety valve in the filler neck as close as possible to the fuel tank(s).
- Prohibitions:**
- 6.7.22. It is not permitted to use the Weber 42DCOE or the equivalent size of carburettor from any other manufacturer.
- 6.7.23. It is not permitted to use the the Cosworth/Richardson down draught F3 MAE head. It is only permitted to use down draught carburettors on those cars so fitted in period (eg Terrier T4 S2 or Ausper T4).
- 6.7.24. Forced induction, fuel injection and external slide throttles are prohibited.
- 6.7.25. The fuel tank must not exceed the originally specified capacity.
- 6.7.26. It is not permitted to relocate the position of the fuel tank.
- 6.7.27. It is not permitted to fit a lambda sensor.

6.8. Cooling system

- 6.8.1. Liquid cooling systems are free provided the radiators are within the overall periphery of the vehicle.
- 6.8.2. Any radiator provided by the manufacturer for the model concerned is authorised but its attachment system must not be modified in any way and its position must not be changed.
- 6.8.3. The addition of a radiator screen is authorised.
- 6.8.4. Aluminium radiators are permitted.
- 6.8.5. Rubber hoses may be replaced with hoses made from silicon. Where possible, black should be selected in preference to any other available colour.

6.8.6. The specification of the coolant utilised is free.

Prohibitions:

6.8.7. It is not permitted to fit an electrical water pump in place of a mechanical driven one.

6.9. Instrumentation

6.9.1. All competitors will be required to fit Electronic Self Identification Modules (transponder) to their cars for the purposes of accurate timing. Holders for these and detailed fitting instructions will be issued with the transponders and it will be the responsibility of the competitor to fit these in the car in the position and manner specified. The Modules must be in place and functioning correctly for all qualifying practice sessions and races. If the car is fitted with the entrant's own permanent transponder, the setting and servicing of these items must only be carried out by properly authorised licensed Timekeepers. Competitors will be charged by the timing company for replacement of the Modules due to misuse or loss.

6.9.2. Mechanical tachometers may be replaced with an electronic tachometer and vice versa.

Prohibitions:

6.9.3. It is not permitted to use any lap timing or datalogging device.

6.9.4. It is not permitted to use an Engine Control Unit, (ECU), traction control or launch control device.

6.10. Gearbox and Transaxles

6.10.1. Subject to paragraphs 6.10.3. and 6.10.4. rear engined cars built after 31/12/1960 (Category FJ2) originally fitted with gearboxes other than Hewland or VW, notwithstanding the general provisions of Appendix K 6.9.5, are not permitted to fit a VW or Hewland gearbox. All cars that have an FIA HVIF in this configuration contrary to period specification are strongly encouraged to revert to their correct and original gearbox and in any event must do so prior to 1st January 2015 for all races, except UK National B races, and in that respect must in any event do so by 1st January 2016.

6.10.2. All cars that have an FIA HTP in this configuration contrary to period specification are strongly encouraged to revert to their correct and original gearbox, and in any event must do so prior to 1st January 2015.

6.10.3. By way of specific exception, a Lotus 20, 22 or a B.M.C. Mk.2 that can on evidence prove that the car was fitted with a VW or Hewland gearbox on or before 31.12.2000, may utilize a VW or Hewland gearbox, provided the number of forward speeds is identical to the number used in period.

6.10.4. Rear engined cars built after 31/12/1960 (category FJ2), originally fitted with a VW or Hewland gearbox may use the Hewland Mk6 or Hewland Mk8 gearbox, which utilised the Volkswagen Beetle casing, provided the number of forward speeds is identical to the number used in period. In all cases such cars are encouraged to use the original gearbox.

6.10.5. The number of forward speeds must be identical to the number used in the period. 5 speed gearboxes are only permitted if period evidence exists that one was used in that particular car/chassis.

6.10.6. It is not mandatory to have a reverse gear.

6.10.7. The gearbox specification shall be for the whole of the FJ2 period (for example, if a Hewland gearbox was originally specified by the manufacturer, the Hewland Mark 4, Mark 6 and the Hewland Mark 8 are permitted for FJ/2 category).

6.10.8. Any car in Class A, B or C fitted with an alternative gearbox to the original gearbox, which would otherwise be eligible for these classes but for the alternative gearbox, shall be admitted to Class D.

When an alternative gearbox is fitted, it must:

6.10.8.1. Be a gearbox that was used in the Formula Junior period.

6.10.8.2. Comply with the original rules of Formula Junior.

6.10.8.3. Only be a gearbox of the same or an earlier period.

6.10.8.4. The number of forward speeds must be identical to the number used in the period.

6.10.9. By way of specific exception, any front engined car fitted with a B.M.C. "A" series gearbox, may utilize a "Rib case" gearbox in place of the "Smooth case" gearbox, provided the number of forward speeds is identical to the number used in period.

- 6.10.10. The Renault Type 318 fitted to Period E cars (category FJ1) can be modified to accept straight cut gears on the basis that the following conditions are adhered to;
 - 6.10.10.1. The standard Renault exterior gearcase casing and end plate are retained (i.e. no modification to the casting profile permitted.)
 - 6.10.10.2. The output shaft side plate must be as the period design (i.e. as per the original Renault Lotus design).
 - 6.10.10.3. The standard crown wheel and pinion (Renault) ratios must be retained.
 - 6.10.10.4. The input shaft must retain a muff coupling.
 - 6.10.10.5. The centres between the layshaft and pinion shaft must remain the same as original.
 - 6.10.10.6. The location of the gear selector rods must remain the same as in the the standard gearbox.
 - 6.10.10.7. The selector mechanism must exit the gearbox housing in the same position as the original design (i.e. at the rear of the gearbox).
 - 6.10.10.8. Only four forward speeds permitted. (Except for those cars proven to have been fitted with the five speed conversion by Jean Redele).
 - 6.10.10.9. The pressed steel covers may be replaced by cast or machined alloy lids.

Prohibitions:

- 6.10.11. Non standard magnesium or light alloy gearbox casings or tail shaft housings are prohibited.
- 6.10.12. It is not permitted to use the Hewland Mark 7 six speed gearbox.
- 6.10.13. It is not permitted to use the Hewland Mark 9 gearbox. This gearbox was not available until 1976.
- 6.10.14. It is not permitted to use a sequential gearbox.

6.11. Final drive and clutch

- 6.11.1. The original clutch control system can be modified. Clutch activation using mechanical means may be converted to hydraulic activation and vice versa.
- 6.11.2. Co-axial hydraulic clutch release systems that utilise an hydraulic release bearing of the direct acting, concentric or co-axial hydraulic slave cylinder type are permitted.

Prohibitions:

- 6.11.3. It is not permitted to use a carbon clutch.
- 6.11.4. It is not permitted to use a titanium flywheel.
- 6.11.5. Limited slip differentials are not permitted.
- 6.11.6. If the original fitment, it is not permissible to replace any Metalastic rubber drive shaft "doughnut" drive shaft couplings (Rotoflex) with a replacement universal joint coupling of the Hardy-Spicer type and a sliding splined drive shaft/yoke.
- 6.11.7. It is not permitted to use the modern type of constant velocity joints on the drive shafts.

6.12. Brakes

- 6.12.1. The braking system and principle, ie, drum brakes or discs, must remain the same as on the car from which the engine is taken.
- 6.12.2. Brake components must be entirely to period specification of the model with the exceptions described here after.
- 6.12.3. Disc brakes are only permitted if a period specification and [with one exception] are only applicable on FJ2 cars. Brake size and type should be as per original specification and should not be increased. This includes both disc and drum-braked cars.
- 6.12.4. Rubber flexible hydraulic pipes may be replaced by smooth bore PTFE (Teflon®) hose with stainless steel outer braid or similar. Where possible, black should be selected in preference to any other available colour.
- 6.12.5. Pressure limiting devices must not be fitted to the hydraulic braking system unless a period specification. Any device allowing the balancing of braking effort between front and rear wheels must not be operable by the driver whilst seated in the driving seat.
- 6.12.6. Brake fluid specification is free.
- 6.12.7. Brake discs must be made from ferrous material.
- 6.12.8. Brake calipers must as per the original specification.

(For example: Brabham Formula Juniors are not permitted to use Girling AR1 calipers and should be fitted with cast iron Girling 12 MP or SP sized calipers. Cooper T59's should be fitted with cast iron Mini Cooper brake calipers). It is advised that these cars revert to the correct specification.

- 6.12.9. Brake shoe/brake pad material is free.

Prohibitions:

- 6.12.10. Vented disc brakes are not permitted. Brake discs must not be modified, i.e. slots and/or grooves in the surface of the disc and cross-drilling is not permitted.
- 6.12.11. Any device operable by the driver, whilst seated in the driving seat which facilitates a change of balance of braking effort between front and rear wheels is not permitted.

6.13. Wheels (see also 8.1.)

- 6.13.1. The maximum rim width permitted in Formula Junior is 5 inches (127mm or 5 J) for Period E (FJ1) cars and 6¹/₂ inches (165mm or 6.5 J) for FIA Period F (FJ2) cars.
- 6.13.2. The above rim widths are MAXIMUM measurements for the category, cars MUST use the same or smaller rim widths as those originally fitted to the car in period.
- 6.13.3. Wheels must be of the same diameter as originally fitted to the car in period.
- 6.13.4. The Osca may use front and rear wheels with the following maximum dimensions: 4¹/₂ inches (114mm or 4.5 J) rim width x 15 inch diameter.
- 6.13.5. The Stanguellini 1100 Corsa in order to use 1 inch wider rims at the front, the front track may be increased from 1220 mm to 1240 mm.
- 6.13.6. Wheels may be of a different type from the ones fitted by the manufacturer provided that the hub remains unchanged as well as the dimensions of the rim and the resulting track is identical to the figures stated by the manufacturer.

Where alternative wheels to the originals are utilised, it is strongly recommended that they are visually sympathetic and complementary to the design of the originals.

Prohibitions:

- 6.13.7. It is not permitted to fit wheels with a wider rim width than was originally fitted to the car in period.
- 6.13.8. The substitution of wire wheels for disc wheels and vice versa is not permitted.
- 6.13.9. Two-part (split-rim) wheels are not acceptable unless of period specification.

6.14. Bodywork

- 6.14.1. All cars must have bodywork to the original silhouette and made from the same material as originally fitted to the car in period.

Prohibitions:

- 6.14.2. It is not permitted to substitute aluminium bodywork for G.R.P. bodywork or vice versa.
- 6.14.3. It is not permitted to add additional air ducts, scoops or blisters.
- 6.14.4. No carbon fibre, Kevlar or composite is permitted in any of the bodywork structure.

6.15. Aerodynamic aids

Prohibitions:

- 6.15.1. No aerodynamic devices may be fitted.

6.16. Electrical system

- 6.16.1. All cars must be equipped with a 6 or 12 volt battery and electrically operated self-starter which must be used to start the car.
- 6.16.2. The original location of the battery may be changed but the battery must be securely fixed and have a leakproof cover.
- 6.16.3. The type, the size and capacity of the battery utilised is free.

6.17. Lighting

- 6.17.1. Not applicable.

6.18. Wheelbase, track, and ground clearance

These regulations MUST be observed.

- 6.18.1. The track and wheelbase must not be altered from the original manufacturer's specification or if this is not available one for which period evidence exists.
The tolerance for the vehicle track is $\pm 1\%$ and the tolerance for the wheelbase is $\pm 1.1\%$, as specified in Appendix K.
- 6.18.2. Minimum track: 110cm.
- 6.18.3. Minimum wheelbase: 200cm.
- 6.18.4. Maximum width of body: 95cm.
- 6.18.5. All sprung parts of the car must have a minimum ground clearance (ride height) of 2.36 inch (60mm), such that a block of 31.5 inch x 31.5 inch x 2.36 inch (800mm x 800mm x 60mm) may be passed underneath the car from any side, at any time of the event. This measurement may be made without the driver but fitted with the wheels and tyres to be used in the competition.
- 6.18.6. The measurement applies to all sprung components, including the "wet" oil sump on Period FJ1 cars, exhaust pipes, inner suspension pick-up points, all bodywork and mounting bolts attached through the floorpan.
- 6.18.7. All measurements must be made while the car is stationary on a flat horizontal surface.

6.19. Weight

- 6.19.1. In accordance with the original Rules of Formula Junior (1958–1963).
- 6.19.2. The minimum weight limit is 880lbs (400Kg). This weight limit however is reduced to 794lbs (360Kg) for cars with a cylinder capacity of 1000cc (1000ml) or less. The above-mentioned weights shall be measured with the car in running order, i.e. with all accessories required by these regulations, but with dry fuel tanks.
- 6.19.3. Ballast may be utilised where it is required to meet/exceed the above minimum weight limits. Refer to 6.2.4.

7. Supplementary Regulations

7.1. Silencer

- 7.1.1. The supplementary regulations of the events may provide that an efficient silencer is compulsory.

7.2. Communication

Prohibitions:

- 7.2.1. Radio communications between cars and pits are forbidden.

8. Tyres

8.1. General

- 8.1.1. Formula Junior cars must use either Dunlop Vintage range tyre R 5 pattern or older or "L" section tyres only which have 204 compound and tread pattern CR65 or earlier.
- 8.1.2. Cars which have wheels with rim widths of 3.5 inch (88,9mm) or less and for which there is no Dunlop Vintage range tyre of a suitable specification available, may use tyres offered for sale as cross ply or radial road tyres, with an aspect ratio of 75% or more, having a speed rating of "S" or above and which have "E" or "DOT" approval. The manufacturer should be consulted as to the suitability of the tyre for the event.

Note: This only applies to some Stanguellini, Volpini and other early Italian cars].

- 8.1.3. Rim widths must not be increased but may be decreased in order to accommodate available tyres. Due regard must be paid to the impact upon the resulting vehicle track, refer to 6.18.1.
- 8.1.4. The interior of the tyre (space between the rim and the internal part of the tyre) must be filled only with air or nitrogen. This does not preclude the use of inner tubes.

Prohibitions:

- 8.1.5. It is not permitted to use any tyre heating/heat retention devices.
- 8.1.6. It is not permitted to use tyre or compound treatments.

9. Final Text

The final text for these regulations shall be the English version which will be used should any dispute arises over their interpretation.

Any alteration or addition not listed above and which has not been subject to a previous written statement of the entrant will entail a penalty which may go as far as exclusion from the competition without prejudice to higher penalties in case of willful misrepresentation.

Contacts:

Technical Officer: Grant Wilson

Chairman : Duncan Rabagliati

FORMULA JUNIOR HISTORIC RACING ASSOCIATION

4 Wool Road, Wimbledon, London SW20 OHW

Telephone: 020 8946 1730

Fax: 020 8946 2367

email: rabagliati@blueyonder.co.uk

Annex A.

The following list of classifications for rear-engined drum-braked cars has been prepared. This list is not exhaustive: in respect of any car not listed, the date of the first race appearance shall be the determining factor.

Class C. FIA Category Period E (FJ/1-R) - Wet sump - Drum Brakes only

Britannia	Fafnir
Caravelle I	Focus (Mk 1, 2 and 3)
Cooper T52 (Mk 1)	Joker
Cooper T56 (Mk 2)	Kieft
Crossle Mk4	MBM
Deep Sanderson	Moretti
De Sanctis (all models with Fiat engine)	Lotus 18
De Tomaso / ISIS (with Fiat engine)	North Star
Dolphin Mk 1	Sauter DKW
Elva 200	Saxon
Emeryson	Wainer (all models with Fiat engine)
Envoy Mk 1	

Note: Any car in the above list fitted with either disc brakes, dry sump, the incorrect gearbox or a Richardson head will be classified in Period F (FJ2) until the specification of that car is corrected.

Class D. FIA Category Period F (FJ2) - Dry sump - Drum Brakes only

Alexis Mk 3	Elva 300
Ausper T3	Envoy Mk 2
BMC Mk 2, Mk3, Mk4 and Mk6	Gemini Mk 3 and 3A
Caravelle II and III	Lola Mk 3
Condor SIII	Lotus 20
Dolphin International (Mk 2 and 2A)	Nota #38

Technical Glossary

Adequate Strength

That the component concerned is of sufficient strength to fulfil the function for which it was intended.

Ballast

Non-functional material added to increase vehicle weight. Any ballast must be permanently fixed to the structure of the vehicle and sealed by Scrutineers' seals.

Bodywork :

All entirely sprung parts of the car in contact with the external air stream, except the roll-over structures and the parts definitely associated with the mechanical functioning of the engine, transmission and running gear. Airboxes and radiators are considered to be part of the bodywork.

British Imperial System

Imperial units or the Imperial system is a collection of units, first defined in the British Weights and Measures Act of 1824, later refined (until 1959) and reduced. The units were introduced in the United Kingdom and its colonies, including Commonwealth countries.

Championship

An event or series of events for the purpose of establishing the right to or collective title.

Chassis

The overall structure of the car around which are assembled the mechanical components and the bodywork including any structural part of the said structure.

Co-axial hydraulic clutch release system

An hydraulic cylinder that fits around the gearbox input shaft.

Cockpit

Structural inner volume which accommodates the driver.

Composite

Material formed from several distinct components, the association of which provides the whole with properties which none of the components taken separately possesses.

Cylinder Volume

The volume swept in cylinder or cylinders by the upward or downward movement of the piston or pistons in relation to such cylinder or cylinders. Cylinder volume shall be expressed in cubic centimetres.

Data Acquisition

The collection and storage of data on a vehicle is termed "data acquisition" or "data logging". Data loggers acquire and store data until the data is downloaded.

Driver (Pilot)

A person nominated as the driver of a vehicle in any event.

Driver Instrumentation.

Driver instrumentation is the medium by which information is displayed to the driver while the vehicle is on the circuit or in the pits/paddock. Driver instrumentation can be driven either by standalone sensors, or driven by a data logger. Sensors to drive the instrumentation are considered as part of the driver instrumentation.

Dry Sump

Any system using a pump to transfer oil from one chamber or compartment to another, to the exclusion of the pump used for the normal lubrication of the engine parts.

Engine Compartment

Volume defined by the structural envelope closest to the engine.

Entrant

The person or body responsible for making an Entry into a Competition and responsible for all matters pertaining to that Entry.

Ferrous

All metals can be classified as Non ferrous metals and Ferrous metals. Ferrous metals are those metals which contain iron and are magnetic e.g. cast iron and steel. Titanium and magnesium are examples of non ferrous metals.

Forced Induction

Any device capable of augmenting atmospheric pressure to increase the induction of air or fuel/air mixture into the combustion chamber (Superchargers, Turbochargers etc.). Ram effects entirely due to the forward motion of the vehicle or tuning of induction or exhaust pipe length are not included within this definition.

“Free” Part

“Free” means that the original part, as well as its function(s), may be removed or replaced with a new part, on condition that the new part has no additional function relative to the original part.

Gauge (see also SWG)

A unit of measurement used for the measurement of thickness sheet and the wall thickness of tubing.

Ground Clearance

The clearance between the ground and the lowest part of the bodywork, or of the suspended part of the car, in normal trim.

G.R.P.

Glass fibre reinforced plastic.

Gusset

A gusset is a device, often triangular, used to reinforce a connection between two components.

Homologation

To approve; confirm or ratify and register (a specific make of automobile in general production) so as to make it eligible for international racing competition.

I.D.

Internal Diameter.

Imperial

See British Imperial System.

Kevlar

Kevlar is the registered trademark for a light, strong para-aramid synthetic fibre. Kevlar was developed at DuPont in 1965 and it was first commercially used in the early 1970's.

LED

A light-emitting diode. Rain lights often use multiple LED's as a small indicator light source.

Light Alloy

Any alloy containing more than 10% aluminium, magnesium or titanium.

Modification

Any change in the design, material, shape, dimensions and/or surface finish of a component, except for basic manufacturing processes, normal wear and published service or repair procedures.

MON

Motor Octane Number (MON) or the aviation lean octane rating, is a better measure of how the fuel behaves when under load. MON testing uses a similar test engine to that used in RON testing, but with a preheated fuel mixture, a higher engine speed, and variable ignition timing to further stress the fuel's knock resistance.

Monocoque

A type of construction in which the body is combined with the chassis as a single unit, in which the skin absorbs all or most of the stresses to which the body is subjected.

O.D.

Outside Diameter.

Parc Ferme

An area designated by and under the control of the organisers and officials of an event into which any entrant or competitor must place the competing vehicle as and when directed by the organizers or officials.

Poly Bushes

Modern oil filled shock absorbers are often supplied with poly propylene bushes.

Ports

Openings and passages in components forming or housing the combustion chambers and/or cylinders through which ingoing and exhaust gasses pass.

Powder coating

Powder coating is a type of dry coating, which is applied as a free-flowing, dry powder. The main difference between a conventional liquid paint and a powder coating is that the powder coating does not require a solvent to keep the binder and filler parts in a liquid suspension form.

Practice

That part of an event intended to enable a competitor to familiarize themselves with the course.

PTFE

Poly(tetrafluoroethene) or poly(tetrafluoroethylene) (PTFE) is a synthetic fluoropolymer which is found in many applications. PTFE's most well known trademark in the industry is the DuPont brand name Teflon.

Radiator

For cooling engine coolants or lubricants (cooler). Not a tank or reservoir.

RON

The most common type of octane rating world-wide is the Research Octane Number (RON). RON is determined by running the fuel in a test engine with a variable compression ratio under controlled conditions, and comparing these results with those for mixtures of iso-octane and n-heptane. In most countries the "headline" octane that would be shown on the pump is the RON.

ROPS

Roll over protection structure. A multi-tubular fabricated structure with connections and suitably rigid fixation points capable of supporting loads fed into them from the roll-over protection structure, designed to offer adequate protection to the driver and to prevent serious deformation in the case of a collision or a car turning over.

Silencer

A sound-reducing device located on an internal combustion engine's exhaust pipe.

Silhouette

The outline of the original body shape, in the side and plan view, of the vehicle above a line permitting closure for motor sporting purposes, where the marking for maintaining a time schedule forms a part of the competition.

Spherical Bearing

Also known by the following proprietary names, Rose joint (UK and elsewhere), Heims joint (N. America), or a Uniball joint. The ubiquity of these manufacturers in their respective markets led to the terms heim joint and rose joint becoming synonymous with their product.

Standard wire gauge (SWG)

British standard wire gauge is a set of wire sizes given by BS 3737:1964, and is generally abbreviated to SWG. Also used for measuring the wall thickness of Imperial size tubing.

Supplementary Regulations (SR's)

Compulsory document issued by the Organisers of a competition with the object of laying down the details of that competition.

Suspension

The system(s) by which sprung movement is provided between the main chassis structure and the road wheels. Suspension will be deemed to consist of all the partly sprung components that move relative to the main chassis structure for the purpose of making connection between it and the entirely unsprung parts but not including components exclusively concerned with steering, braking and power transmission.

Sump

The elements bolted below and to the cylinder block which contain and control the lubricating oil of the engine.

Telemetry

Telemetry is the means of transfer of information and/or data from a data source to a data receiver without a cable. In motor sport applications, the term telemetry usually refers to "unidirectional transfer of data to the pits whilst the vehicle is on the circuit, without any acknowledgement signal being transmitted by the pit based equipment.

Transponder

In telecommunication, the term transponder (short-for Transmitter-responder) is an automatic device that transmits a predetermined message in response to a predefined received signal. Used for the purpose of lap timing.

Wet Sump

A wet sump is a lubricating oil management design for four-stroke piston internal combustion engines which uses a built-in reservoir for oil, as opposed to an external or secondary reservoir used in a dry sump design.

Wheelbase

The wheelbase is the horizontal distance between the centre of the front wheel, and the centre of the rear wheel.